

MODEL NO.: KFKHQ-3

DESIGN DATA

Sr No.	PARTICULARS	DESCRIPTION
01	Capacity	3 Ltr.(Tolerance ±5% by Volume)
02	Temperature range	+5°C to +55°C
03	Service pressure	9 bar
04	Maximum service Pressure	15 bar
05	Pressure test (PT)	35 bar (3.5 MPa)
06	Minimum Burst Pressure of Body (PB)	55 bar (5.5 MPa)
07	Burst pressure of hose	Not less than 35 bar (3.5 MPa)

PERFORMANCE PARAMETERS

01	Effective discharge time	12 Sec. (Approx.)
02	Bulk range of discharge	3 meter (Approx.)
03	Percentage of discharge	Not less than 90%
04	Applicable class of Fire	K (Kitchen Fires)

16.	Extinguishing medium	Wet Chemical (Blend of Potassium Acetate, Citrate or Carbonate)
15.	Wall bracket with Screw	Mild steel (Powder coated) / M.S
14.	Safety pin Holder	Rubber/Soft pvc
13.	Safety pin	S.S.
12.	Seal	Plastic
11.	Belt	Pvc
10.	Siphone tube	S.S.
09.	Pressure gauge/Indicator	Brass
08.	Discharge Nozzle	S.S.
07.	Discharge hose	Rubber Braided EPDM Hose
06.	Strainer	S.S.
05.	"O" Ring	Nitryle Rubber
04.	Valve	Brass
03.	Lever lock	Plastic
02.	Neck ring	S.S.Pipe
01.	Body	S.S. Sheet

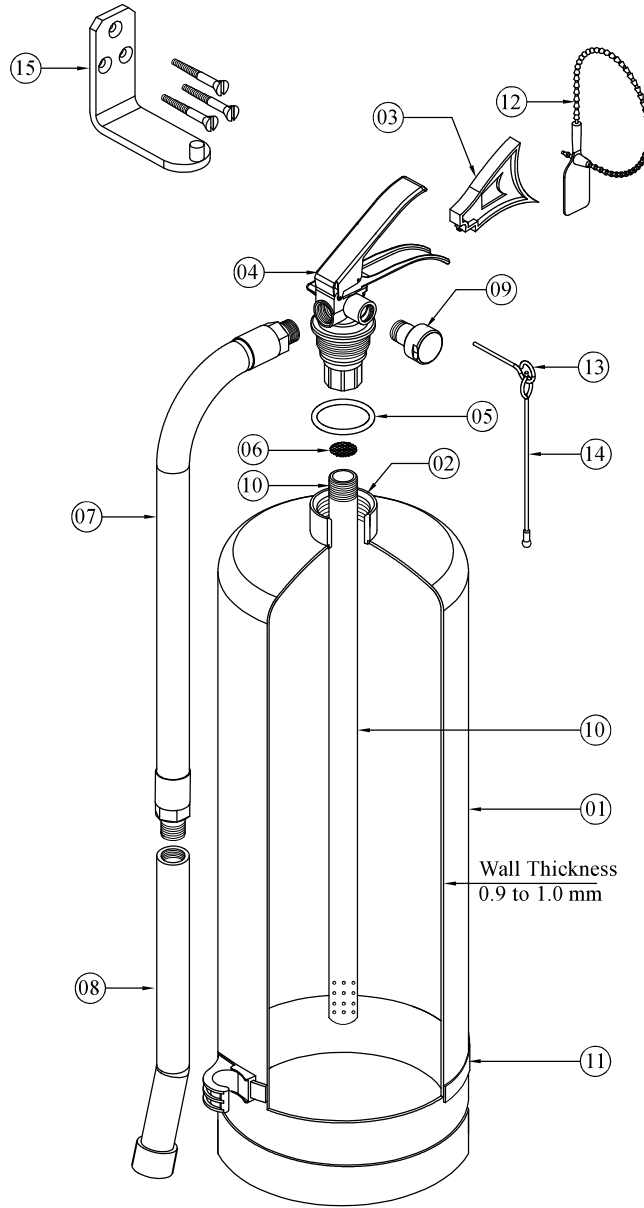

Wall Thickness  
0.9 to 1.0 mm



XXX XXX XXX XX XXX

XXX XXX XXX XX XXX

XXX XXX XXX XX XXX

XXX XXX XXX XX XXX

00.00.00	00.00.00		APP'D	A. Shah	08.11.16
00.00.00	00.00.00		CHK'D	Naresh	08.11.16
00.00.00	00.00.00		DR'N	RNG	08.11.16

**KANEX**  
KANADIA FYR FYTER PVT.LTD  
(AN ISO-9001:2008 CERTIFIED CO.)  
PLOT NO - 7, PARAS IND. ESTATE, NEAR GARIBSHA PIR,  
SHJOR -364 240.(GUJ.) e-mail: tech@kanexfire.com

K CLASS WET CHEMICAL KITCHEN FIRE EXTINGUISHERS OF CAPACITY 3 LTR.

DRG. NO.: KFPL/GAD/KFKHQ-3

Scale	NTS
Project	
Sheet	REV.
1 of 1	00

Sr.No	Item Description	Materials of Constructions
-------	------------------	----------------------------